

# Multi-Axis Servo Robots for Horizontal Injection Molding Machines

**ERC 23-53 C**

**ERC 23-33 CH**

**ERC 63-83 C**

**ERC 103-303 N**

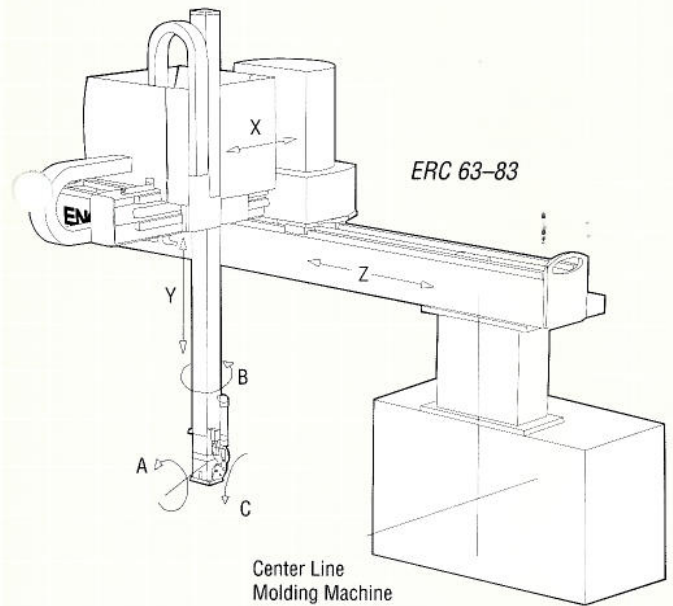
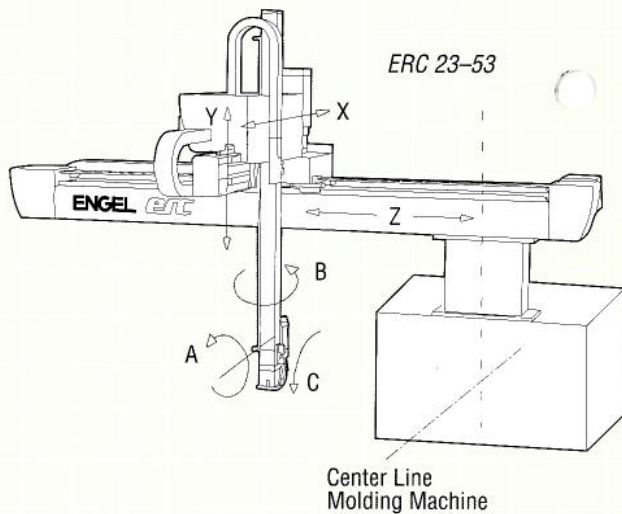

TYPE		ERC 23/1-C	ERC 23/1-CH	ERC 33/1-C	ERC 33/1-CH	ERC 43/1-C	ERC 53/1-C	ERC63/1-C	ERC63/1-PL
Payload max.	(lbs.)	22	6.6	22	6.6	22	22	56	56
Positioning accuracy	(in.)	±0.004	±0.004	±0.004	±0.004	±0.004	±0.004	±0.004	±0.004
X-axis (Demolding) stroke	(in.)	11.81	11.81	15.75	15.75	19.68	25.59	25.59	25.59
X-axis Max. speed	(in./sec.)	78.74	118.1	78.74	118.1	78.74	78.74	78.74	78.74
Y-axis (Vertical) stroke	(in.)	31.50	31.50	39.37	39.37	39.37	51.18	39.37	39.37
Y-axis Max. speed	(in./sec.)	78.74	157.50	78.74	157.50	78.74	78.74	98.43	98.43
Z-axis (Crosstransport) stroke	(in.)	55.12	55.12	64.57	64.57	74.01	92.91	78.74	78.74
Z-axis Max. speed	(in./sec.)	78.74	145.70	78.74	145.70	78.74	78.74	82.68	82.68
C-axis (0° → 90°)	(ft.-lbs.)	7.4	2.7	7.4	2.7	11.1	11.1	40.6	40.6
	(ft.-lbs.)	11.1 opt.		11.1 opt.					
Air consumption	(in. <sup>3</sup> )	214	214	214	214	214	214	245	245
Power supply	(kVA)	3	3	3	3	3	3	4	4
Transport weight	(lbs.)	550	550	600	600	660	800	1320	1320
Transport weight control cabinet	(lbs.)	420	420	420	420	420	420	420	420
Suitable for machine	(tons)	40 - 100	40 - 100	150 - 300	150 - 300	300 - 500	400 - 600	300 - 500	300 - 1000