



INSTRUCTION SHEET

Bulletin No. 1515093

O10/O16/O20/O60 Commercial Temperature Controls

DESCRIPTION/APPLICATION

RANCO commercial temperature controls are used in commercial refrigeration, air conditioning, heating and ventilating applications. Their sensing elements contain a refrigerant charge which develops pressure relative to the temperature being sensed. This pressure operates the switch located within the control.

These controls, with NEMA I enclosures and snap action switches are used in a variety of applications: direct control of motors, compressors, fans, heating equipment, etc.; pilot duty control of a contactor; control of solenoid valves. The electrical ratings shown inside the control cover must not be exceeded.

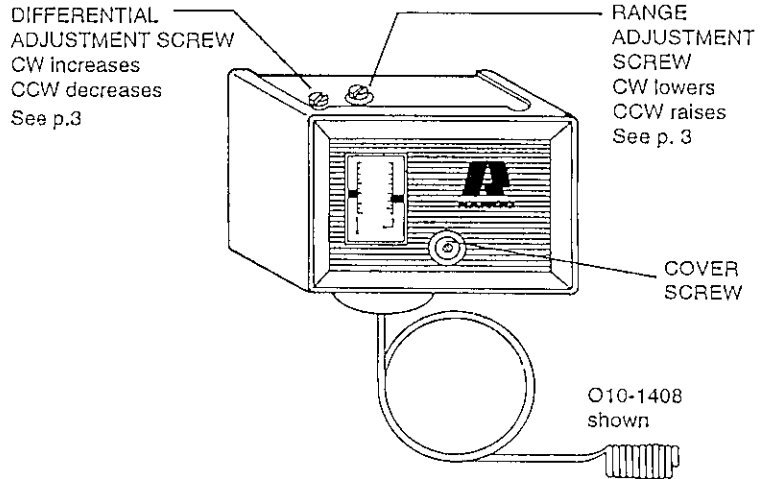

O10 Single pole, single throw (SPST)
close (cut-in) on rise
open (cut-out) on drop



O16 & O60 Single pole, double throw (SPDT)
2-3 close on rise; open on drop
2-1 close on drop; open on rise

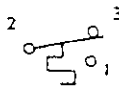

O20 Double pole, single throw (DPST)
close (cut-in) on rise
open (cut-out) on drop

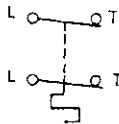

INSTALLATION

CAUTION:

To prevent possible electrical shock or equipment damage, disconnect electrical power to unit before and during installation. **DO NOT** restore electrical power to unit until the control is properly installed and grounded. **DO NOT** locate the control in an explosive atmosphere as a safety hazard can result due to possible spark generation in the control.

Controls are not to be located in areas of extreme moisture, dirt or dust, or in a corrosive or explosive atmosphere. These environments can shorten control life.

All O series are available in the automatic reset/cycling version. Manual reset versions of the O16 are available.

IMPORTANT NOTICE MANUAL OPERATION (tripping switch)

If the switch is open (terminals 2-3 on O16 & O60) it can be manually closed by lifting the bellows tab as shown.

Operating the control at any other point WILL CAUSE CONTROL DAMAGE AND VOID THE WARRANTY.

DO NOT REMOVE the protective switch cover.

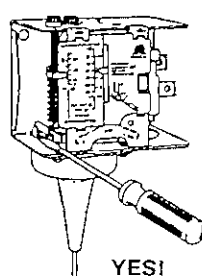
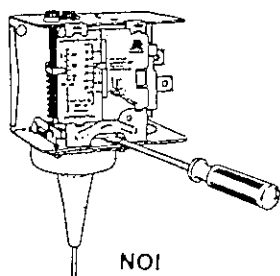
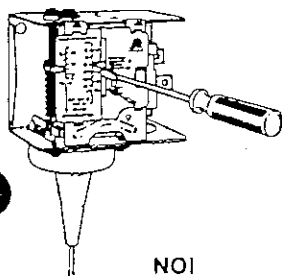

CONTROL BODY MOUNTING

Select a location that will permit proper capillary routing. It is important not to twist or strain the control body as shifting of the calibration may result.

RANCO temperature controls can be mounted in any position without affecting performance. They can be mounted on an existing bracket or on the bracket provided which may be attached to the control either vertically or horizontally as best fits the application. The control may also be mounted directly to any flat surface. Whichever method is selected, use only the mounting holes provided in the control frame. No other holes are to be added.

When attaching the control to a bracket, use the screws provided and the two tapped holes in the back of the control. If other mounting screws are used, they must not enter the control more than 1/8" to avoid damage.

When surface mounting the control, use the .20 inch holes in the back of the control frame which can be accessed by removing the front cover. Make sure the surface is flat. Mounting to an uneven surface may cause improper control operation.

SENSING ELEMENTS

There are several forms of sensing elements used on the O series, but there are only two basic types: limited vapor-fill and cross ambient. See page 4 for important tips on control selection.

LIMITED VAPOR-FILL TYPE sensing elements

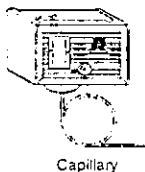

Capillary

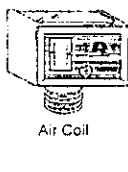

Air Coil

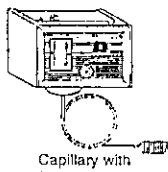

Capillary with Remote Bulb

1. Limited vapor-fill sensing elements always sense from the coldest section including the control body if it becomes coldest. Do not let any part of the capillary touch anything that is colder than the desired sensing section.
2. Air coil sensing elements are to be used as supplied. The capillary is not intended to be unwound.
3. When sensing an evaporator or similar surface, make certain that the bulb or at least 6" of capillary is in good contact with it. DO NOT crush or deform the sensing element when clamping it. Sensing may be improved by insulating the sensing section and area from the environment.
4. When sensing a well, the bulb or at least 10" of capillary should be in good contact with the inner wall of the well. Use sealant to prevent water from entering or condensing in the well.
5. When sensing a liquid, the entire bulb or at least 4" of capillary should be immersed.

SENSING ELEMENTS (limited vapor-fill) cont'd

6. When sensing air with the capillary-type or remote bulb-type, at least 18" of capillary or the bulb with an additional 8" of capillary should be in the air stream.
7. When the capillary sensing section is routed upward, an "S" bend or "U" must be provided.



If remote-bulb style, the bulb should be horizontal or pointed downward. These considerations prevent the sensing element charge from flowing away from the sensing section and causing erratic operation.

CROSS AMBIENT TYPE sensing elements

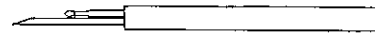

Cross ambient sensing elements always sense from the bulb. The bulbs used on Ranco 'O' series cross ambient temperature controls are 3/8" diameter by 6" long and can be mounted in any position. DO NOT heat the bulb above 150°F and take care to not deform or cut it.

The entire bulb is required for proper sensing. When sensing an evaporator or similar surface, it should be securely clamped to the surface. Sensing may be improved by insulating the bulb and the surface being sensed from the environment. If sensing a well, the bulb should be in good contact with the inner wall of the well and the well should be sealed to prevent the entrance of moisture.

CAPILLARY CARE AND MOUNTING

1. When uncoiling the capillary (air coil-type are not to be uncoiled), hold the capillary close to the bellows and carefully uncoil the required amount. Minimize rebending of the capillary which makes it more susceptible to breakage.
2. DO NOT cut the capillary or bulb. Avoid sharp bends, kinks, strains, or pinch marks in the capillary. Never allow the capillary to rest against sharp edges or rub against metal surfaces.
3. Avoid exposing the capillary to extreme temperatures such as suction and discharge lines.
4. A drip loop should be provided in the capillary to prevent moisture from reaching the control and causing an electrical short.
5. Excess capillary does not affect the setting or operation. Secure any excess capillary in 3 inch coils to avoid damage from vibration or contact with electrical terminals. Silicone adhesive applied between the coils will prevent rubbing.
6. Although coiling and securing the excess capillary is important to dampen the effects of vibration, it is just as important to allow enough slack so the capillary is not taut like a "banjo string".
7. On startup of the equipment, observe the capillary for excessive vibration and make corrections as required.

CONTROL WIRING

1. Disconnect electrical power to the unit.
2. All electrical wiring should conform to the National Electrical Code and local regulations.
3. The electrical ratings shown inside the control cover must not be exceeded. See below for DC ratings.
4. Use copper conductors only.
5. When mounting a conduit connector to the control frame, take care to not damage the switch or the control mechanism.
6. The terminals must not be bent, cut off, drilled or retapped. Electrical leads should not be taut; allow slack for temperature change and vibration. Provide a drip loop in the wiring to prevent water from reaching the control.
7. Attach electrical leads to the switch terminals using the screws provided (see below for O16 & O60).

The furnished cup washers are to be used on the O16 and O60 when the conductor wires are directly connected to the terminals. The stripped end of the conductor should be made into a clockwise formed eye with an inside diameter to slip over the shank of the terminal screw. The cup washer, with its flanges outward, should be placed between the terminal and the screw head to capture the eye of the conductor.

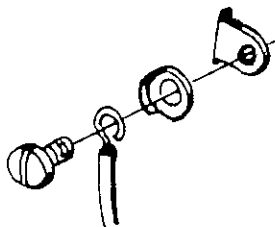

DC RATINGS (For AC, see inside of control cover)

	Volts	FLA	LRA	NIA	PD VA
O10	32	9.3	93		
With 1397004-2 magnet package installed	72	7.3	73		
	115	4.6	46		57.5
	230	2.3	23		57.5
	120	4.6	46	3	57.5
O20	240	2.3	23	0.5	57.5
	600				57.5

CONTROL SETTINGS AND ADJUSTMENTS

ALL CONTROL SETTINGS are to be as specified by the equipment manufacturer and as required for the application. DO NOT adjust the pointers beyond the highest and lowest marks on the scaleplate. The scaleplate is only for reference and the final settings should be verified with a thermometer. As a final check, the system should be run through several cycles to assure proper settings and installation.

On automatic reset controls, the Range scale (R.H. pointer) indicates the temperature at which the control will cut-in (using terminals 2-3 on O16 & O60). The cut-out is the range setting minus the differential. The differential may be adjustable or fixed, depending on the control.

CONTROL SETTINGS AND ADJUSTMENTS cont'd

CLOSE ON RISE CONTROLS with Automatic reset O10 and O20; O16 & O60 terminals 2-3

The scaleplate directly indicates the **cut-in** and **differential**. The cut-out is calculated by subtracting the differential from the cut-in:

- 1) Adjust the **range** screw until the scale pointer indicates the desired **cut-in** setting.
- 2) Adjust the **differential** screw until the scale pointer indicates the desired **differential** setting. The cut-out setting equals the **cut-in** setting, less the **differential**.

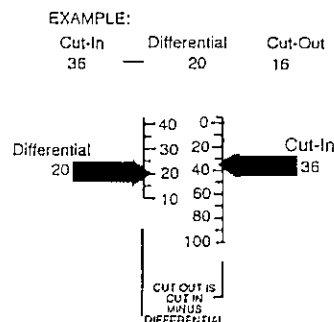

LOWEST EVENT: DO NOT set the control below the lowest event. On automatic reset controls, (with adjustable differential), if the combination of the Range (R.H. pointer) minus the Differential (L.H. pointer) is lower than the lowest temperature shown on the Range scale, the control may not operate. For example, if the Range of the control is 0 to 55°F, do not set the combination of range minus differential below 0 degrees. If lower settings are required, select a different control.

The scaleplate on manual reset controls indicates the temperature that terminals 2-3 will lock open on temperature drop. The temperature must rise approximately 3 degrees above this setting before the control can be reset.

DIFFERENTIAL

On controls with an adjustable differential, the smallest differential occurs when the differential spring is completely relaxed and no longer a factor in the operation of the control. This is accomplished when the differential spring hook no longer engages the pickup arm (see below). The differential should not be set narrower than this, otherwise the spring may interfere with the upward movement of the pickup arm.

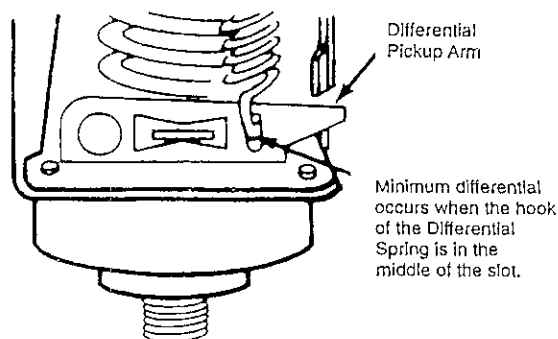

ALTITUDE CORRECTION

Altitude will cause the control to operate approximately 1°F colder per 1000 feet of elevation. Normally, the altitude effect is not a factor since the control is set and used at the same altitude. It is only a consideration when the control is set and then moved to another elevation.

TIPS ON TEMPERATURE CONTROL SELECTION

A limited vapor-fill control may be used on any application where the desired sensing is at the coldest point along the capillary (including the control body itself). An example of a proper application would be sensing the evaporator, the air within a fixture, or a well within a fixture where the remaining capillary and the control body is never colder than the desired sensing section. Another example is when the entire control is located within a fixture.

A cross ambient control is needed when the place being sensed can become warmer than the remaining capillary or the control body. Examples of these applications are: defrost termination/fan delay control, since the evaporator becomes warmer than the space during defrost; bulk milk coolers which are located in buildings that may be colder than the stored milk; control of various heating devices; situations where the control body is located outside the fixture (refrigerated or heated) where it can become colder than the temperature of the fixture that it is controlling.

Control selection is important to obtain the desired differential (differential is the difference between the cut-in and cut-out). When the control is sensing product, the air within a fixture, or the air returning to an evaporator, a narrow differential (about 5°F or less) is required to closely maintain the product temperature. When the control is sensing the evaporator, a wide differential (about 10°F or more) is required due to the swing in the evaporator temperature between the time the compressor is on and when it is off. Limited vapor-fill controls inherently have a narrower differential at the warmer end of their range than at the colder end. If the differential is set when the control is at the warm end of the range, the differential will increase if the range is adjusted colder. If a narrow differential is required, select a control that will operate at the warmer end of its range.

SPECIFICATIONS

Controls listed are limited vapor-fill type unless otherwise noted. See page 2 for more description.

Applications	Range (°F)	Differential (°F)	O10			O16			O20
			SPST - Opens Low			SPDT - Opens High or Low			DPST - Opens Low
			72" Capillary	Air Coil	72" Capillary Remote Bulb	72" Capillary	Air Coil	72" Capillary Remote Bulb	96" Capillary 3/8 x 6" Cross Ambient Bulb
Extra Low	-55 to 0	3 to 20▲	O10-1000	-	-	-	-	-	-
	-35 to 15		O10-1419	-	O10-1433	-	-	-	-
Low	-15 to 40	3 to 20▲	-	O10-1072	O10-1406	-	-	-	-
		1.5 Fixed	-	-	-	O16-588	-	-	-
Medium	0 to 55	1.5 Fixed	-	-	-	-	-	O16-601†	-
		3 to 20▲	O10-1416	O10-1418	O10-1409	O16-111	-	O16-104	-
		7 to 55	O10-1010 48" Cap	-	O10-1473	-	-	-	-
		2 Fixed	-	-	O10-1490	-	O16-594	-	-
		Manual Reset** (Freeze Protection)	-	-	-	O16-264 96" Cap	-	O16-263	-
Medium/High	0 to 100	6 to 20	-	-	-	-	-	O20-7041	
High	25 to 75	3 to 20▲	-	O10-1802	O10-1410	-	-	-	-
		2 Fixed	-	-	O10-1491	-	-	-	-
	30 to 90	2.5 Fixed	-	-	-	-	O16-165	-	-
	50 to 105	3 to 20▲	-	-	-	-	O16-595	-	-

† 36" Cap. 3/8 x 6" Bulb

**Locks on temperature decrease

▲ Differential at the low end of range is 6 to 25



Range (°F)	Differential (°F)	O60		
		SPDT Opens High or Low		
		96" Capillary 3/8 x 6" Cross Ambient Bulb	240" Capillary 3/8 x 6" Cross Ambient	Air Coil
-35 to 95	4 to 50	O60-100	O60-120	O60-101
95 to 240	6 to 50	O60-200	-	-

RANCO CONTROLS

RANCO WHOLESALE
Uni-Line Div. Robertshaw
8115 U.S. Route 42 North
Plain City, Ohio 43064
(614) 876-8022

Copyright 1989, Ranco Incorporated
All Rights Reserved
Form #1515093
Rev. E89